

# 2024 Financial Management Conference

## CDFI Ratings Panel

**Moderator,** Matt Glattig, NeighborWorks Capital

**Panelists,** Debra Turner, Community Housing Capital, Nora Wittstruck, S&P Global Ratings

Sept. 4, 2024

**STRENGTHMATTERS**<sup>®</sup>



# Continuing Professional Education (CPEs) Requirements for CPAs

- Please find the **SESSION HOST** to **SIGN IN** at the beginning and **SIGN OUT** at the end of every session using the QR code. We use that attendance log to verify your participation for CPE credits.
- Please **submit all conference evaluations**. Evaluation links are emailed to registrants daily. Please see the session host (the person monitoring the sign-in process) if you prefer a paper evaluation.
- For more information on CPE credits, contact Lindsay Wells at [consult.lwells@gmail.com](mailto:consult.lwells@gmail.com).

# Questions

- We will pause during presentation and again at the end for Q&A.

# Strength Matters Conference



**Nora Wittstruck**  
**Managing Director, Sector Lead**  
September 4, 2024

# Americas Public Finance | Housing Team

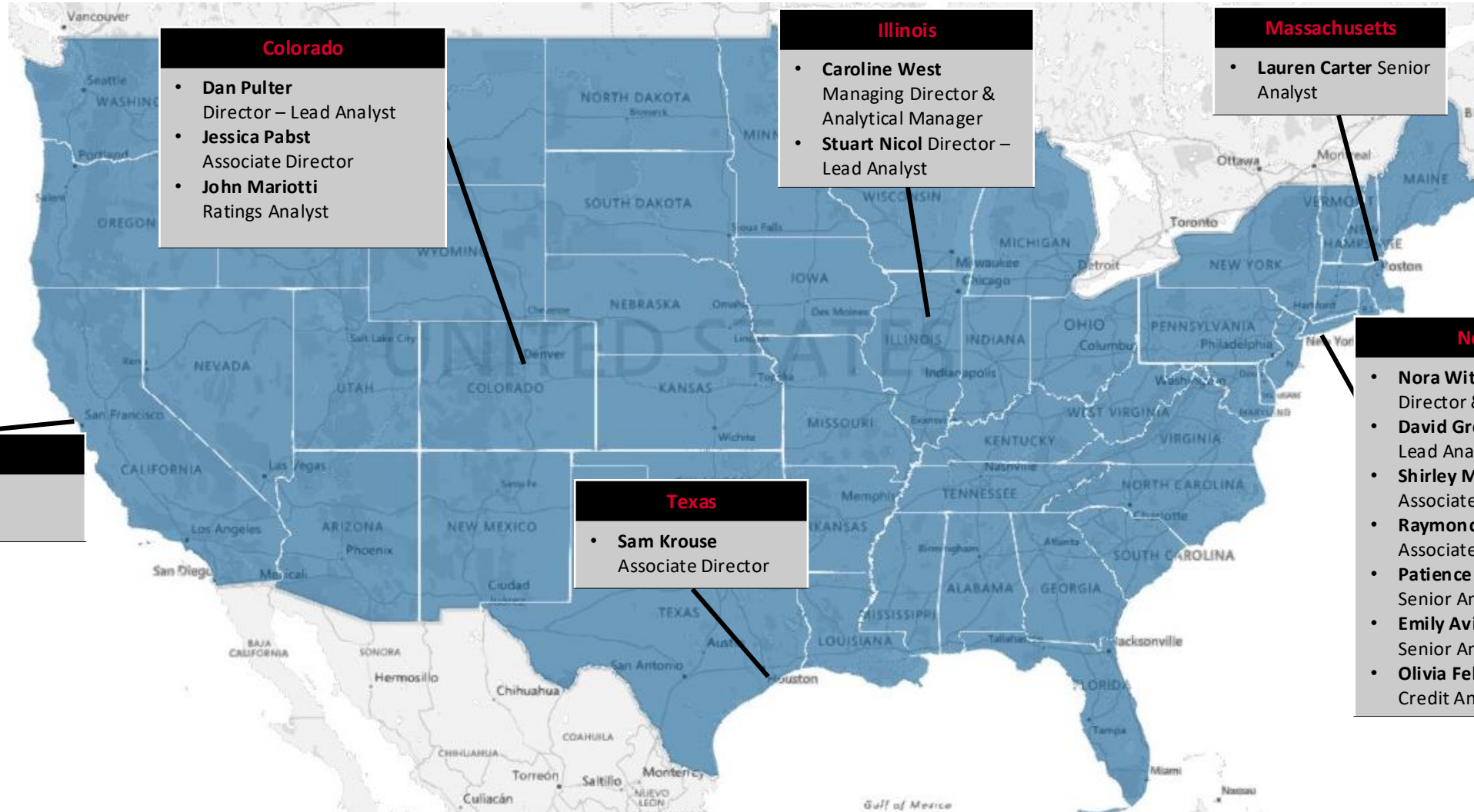

# Ratings in Perspective | as of Aug. 28, 2024

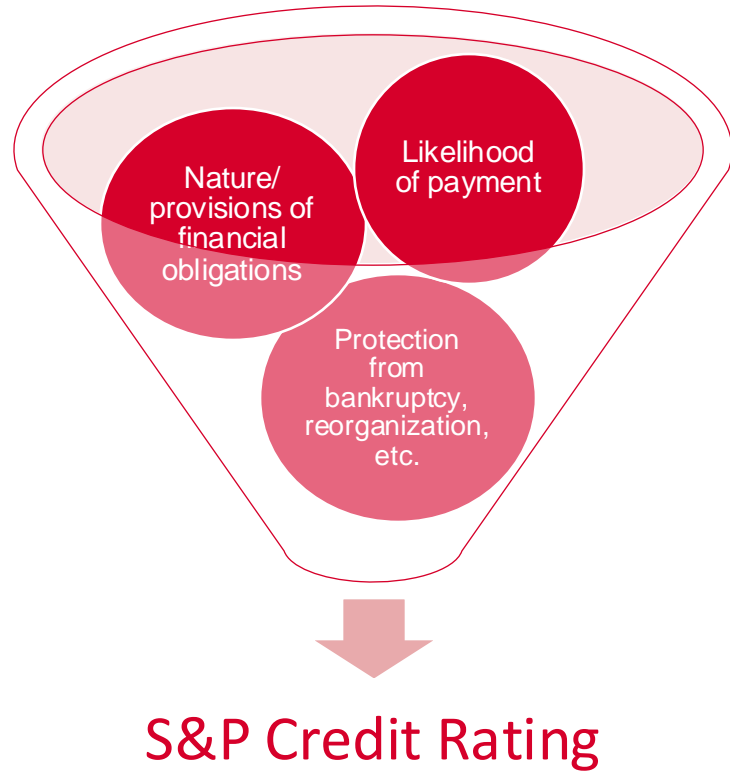

S&P Rating	
AAA	 Microsoft 
AA+	   <div style="border: 1px solid gray; padding: 2px;">Median HFA MRB Issue Rating</div>
AA	  <div style="border: 1px solid gray; padding: 2px;">Median HFA Issuer Rating</div>
AA-	   <div style="border: 1px solid gray; padding: 2px;">Median SHP and CDFI Issuer Rating</div>
A+	  
A	   
A-	   
BBB+	  

# S&P Global's Ratings Scale

## Investment-Grade

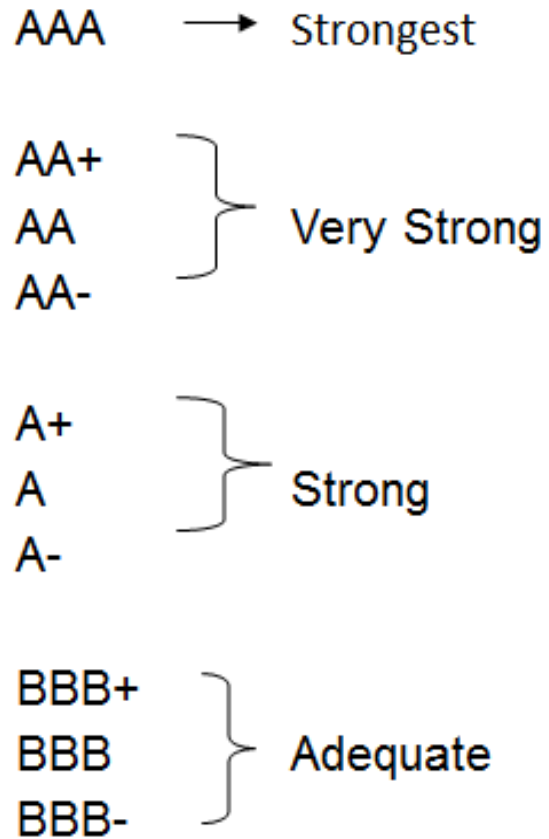

## Speculative-Grade

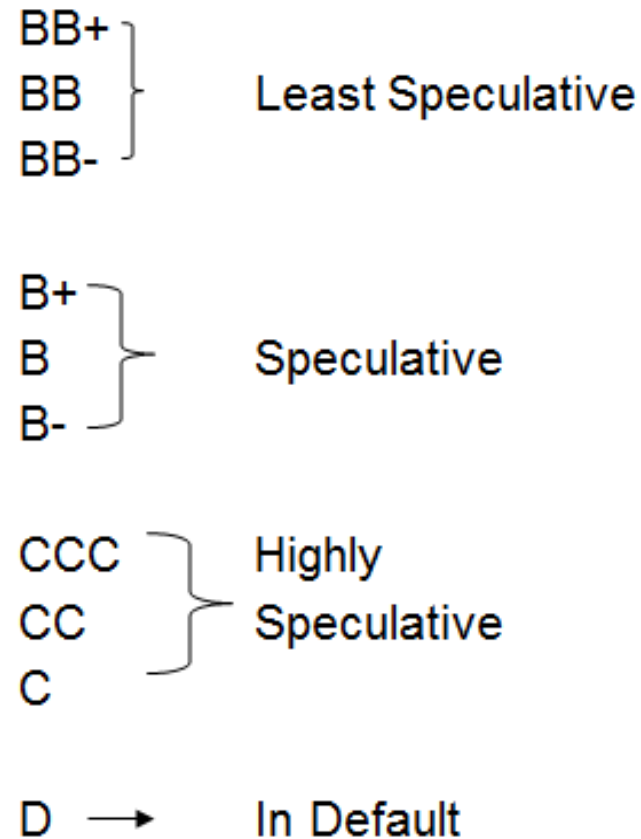

Short-term U.S. Public Finance note ratings: **SP-1+, SP-1, SP-2 & SP-3**

# Ratings Process – Pre-Committee

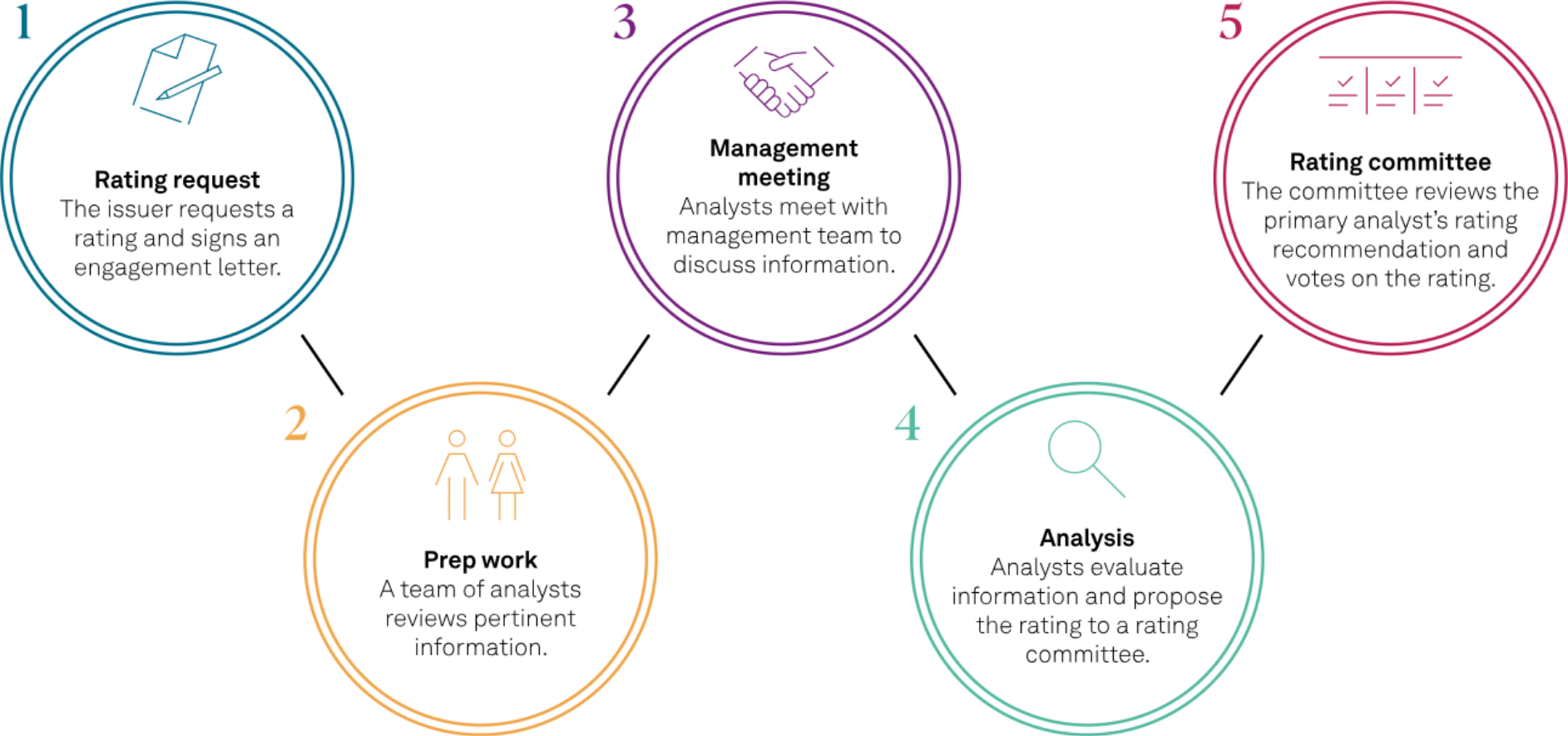

Source: S&P Global Ratings.  
Copyright © 2023 by Standard & Poor's Financial Services LLC. All rights reserved.



# Ratings Process – Post Committee



Source: S&P Global Ratings.  
Copyright © 2023 by Standard & Poor's Financial Services LLC. All rights reserved.

# Credit Analysis for CDFIs

To determine a CDFI's ICR, we consider:

- Financial strength
- Management
- Economy

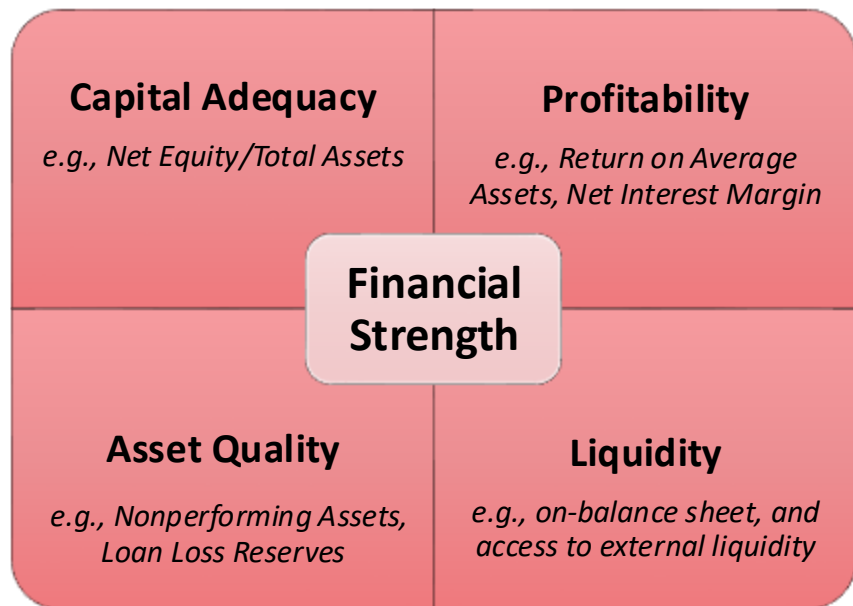

**As of Aug. 2023:**

## Community development financial institutions (CDFIs)--by the numbers



**A+**

average rating



**13**

rated CDFI organizations



**9**

years weighted average loan term



**26%**

of median loan balance vs. 8% of median debt maturing within one year



**41%**

median revenue derived from loan interest income

### Year-over-year changes (2022 vs. 2021)



**9%**

increase in median equity



**8%**

increase in median debt outstanding



**3%**

increase in median gross loan balance



**20**

basis points decrease in median NPAs to total loans and real estate owned



**12**

basis points median decrease in weighted average loan interest rate

Source: S&P Global Ratings.

Copyright © 2023 by Standard & Poor's Financial Services LLC. All rights reserved.

# Credit Analysis for PHAs and nonprofit social housing providers/developers

## Overview Of Framework For Rating Public And Non-Profit Social Housing Providers

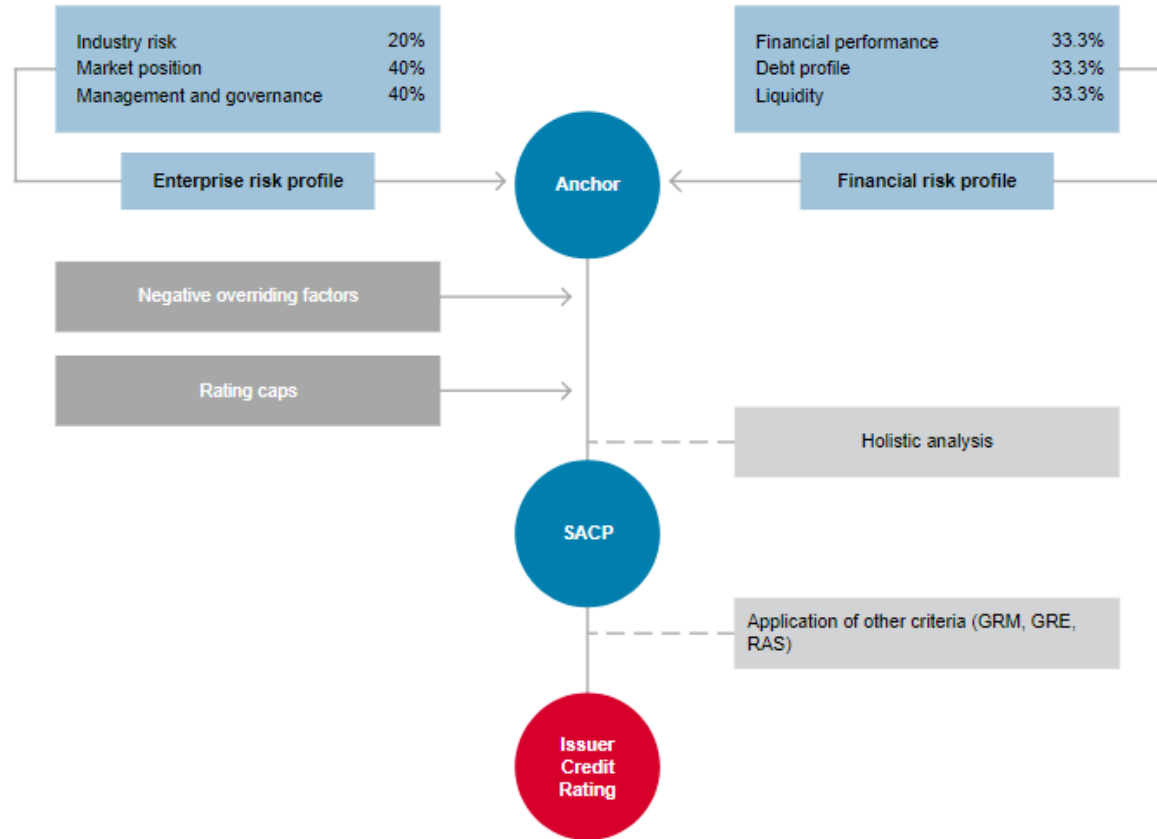

Source: S&P Global Ratings.  
Copyright © 2021 by Standard & Poor's Financial Services LLC. All rights reserved.

## As of Oct. 2023:

### U.S. social housing providers by the numbers

#### Overview

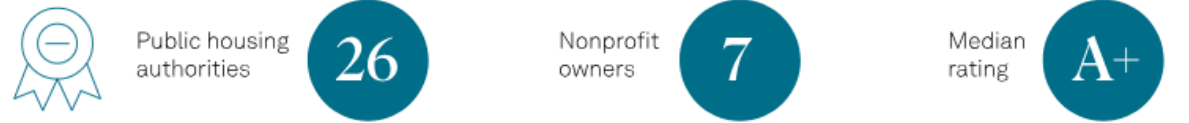

#### Portfolio overview



### Rated bond issuance by purpose

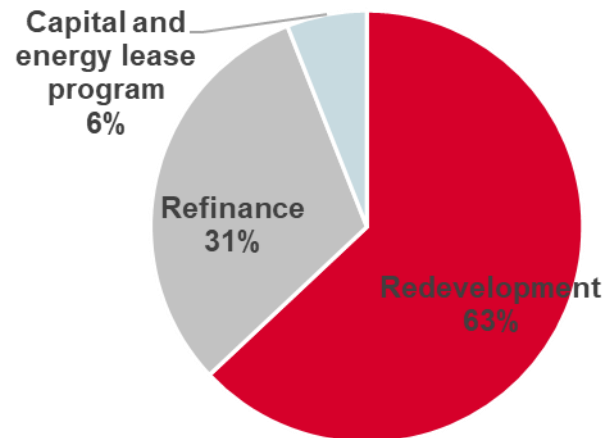

Copyright © 2024 by Standard & Poor's Financial Services LLC. All rights reserved.

No content (including ratings, credit-related analyses and data, valuations, model, software or other application or output therefrom) or any part thereof (Content) may be modified, reverse engineered, reproduced or distributed in any form by any means, or stored in a database or retrieval system, without the prior written permission of Standard & Poor's Financial Services LLC or its affiliates (collectively, S&P). The Content shall not be used for any unlawful or unauthorized purposes. S&P and any third-party providers, as well as their directors, officers, shareholders, employees or agents (collectively S&P Parties) do not guarantee the accuracy, completeness, timeliness or availability of the Content. S&P Parties are not responsible for any errors or omissions (negligent or otherwise), regardless of the cause, for the results obtained from the use of the Content, or for the security or maintenance of any data input by the user. The Content is provided on an "as is" basis. S&P PARTIES DISCLAIM ANY AND ALL EXPRESS OR IMPLIED WARRANTIES, INCLUDING, BUT NOT LIMITED TO, ANY WARRANTIES OF MERCHANTABILITY OR FITNESS FOR A PARTICULAR PURPOSE OR USE, FREEDOM FROM BUGS, SOFTWARE ERRORS OR DEFECTS, THAT THE CONTENT'S FUNCTIONING WILL BE UNINTERRUPTED, OR THAT THE CONTENT WILL OPERATE WITH ANY SOFTWARE OR HARDWARE CONFIGURATION. In no event shall S&P Parties be liable to any party for any direct, indirect, incidental, exemplary, compensatory, punitive, special or consequential damages, costs, expenses, legal fees, or losses (including, without limitation, lost income or lost profits and opportunity costs or losses caused by negligence) in connection with any use of the Content even if advised of the possibility of such damages.

Credit-related and other analyses, including ratings, and statements in the Content are statements of opinion as of the date they are expressed and not statements of fact. S&P's opinions, analyses, and rating acknowledgment decisions (described below) are not recommendations to purchase, hold, or sell any securities or to make any investment decisions, and do not address the suitability of any security. S&P assumes no obligation to update the Content following publication in any form or format. The Content should not be relied on and is not a substitute for the skill, judgment and experience of the user, its management, employees, advisors and/or clients when making investment and other business decisions. S&P does not act as a fiduciary or an investment advisor except where registered as such. While S&P has obtained information from sources it believes to be reliable, S&P does not perform an audit and undertakes no duty of due diligence or independent verification of any information it receives. Rating-related publications may be published for a variety of reasons that are not necessarily dependent on action by rating committees, including, but not limited to, the publication of a periodic update on a credit rating and related analyses.

To the extent that regulatory authorities allow a rating agency to acknowledge in one jurisdiction a rating issued in another jurisdiction for certain regulatory purposes, S&P reserves the right to assign, withdraw, or suspend such acknowledgment at any time and in its sole discretion. S&P Parties disclaim any duty whatsoever arising out of the assignment, withdrawal, or suspension of an acknowledgment as well as any liability for any damage alleged to have been suffered on account thereof.

S&P keeps certain activities of its business units separate from each other in order to preserve the independence and objectivity of their respective activities. As a result, certain business units of S&P may have information that is not available to other S&P business units. S&P has established policies and procedures to maintain the confidentiality of certain nonpublic information received in connection with each analytical process.

S&P may receive compensation for its ratings and certain analyses, normally from issuers or underwriters of securities or from obligors. S&P reserves the right to disseminate its opinions and analyses. S&P's public ratings and analyses are made available on its Web sites, [www.spglobal.com/ratings](http://www.spglobal.com/ratings) (free of charge) and [www.ratingsdirect.com](http://www.ratingsdirect.com) (subscription) and may be distributed through other means, including via S&P publications and third-party redistributors. Additional information about our ratings fees is available at [www.spglobal.com/ratings/usratingsfees](http://www.spglobal.com/ratings/usratingsfees).

Australia: S&P Global Ratings Australia Pty Ltd holds Australian financial services license number 337565 under the Corporations Act 2001. S&P Global Ratings' credit ratings and related research are not intended for and must not be distributed to any person in Australia other than a wholesale client (as defined in Chapter 7 of the Corporations Act).

STANDARD & POOR'S, S&P and RATINGSDIRECT are registered trademarks of Standard & Poor's Financial Services LLC.

**[spglobal.com/ratings](http://spglobal.com/ratings)**

# Evaluation Reminder

- Please submit all conference evaluations. Use the electronic evaluation link in your email.
- Contact [consult.lwells@gmail.com](mailto:consult.lwells@gmail.com) if you do not receive the link.

# CONTACT INFORMATION

**Debra Turner**

dtturner@communityhousing.org

**Nora Wittstruck**

nora.wittstruck@spglobal.com

**Matt Glatting**

mglatting@neighborworkscapital.org

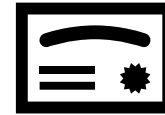

**Lindsay Wells**

*(CPE credit contact)*

[consult.lwells@gmail.com](mailto:consult.lwells@gmail.com)

